

MODELLO MODEL	CODICE CODE	COMPRESA UNITA' CONDENSATRICE A BORDO			ESCLUSA UNITA' CONDENSATRICE	COMPRESA UNITA' CONDENSATRICE REMOTA ERMETICA <i>fino a 20 metri</i>		COMPRESA UNITA' CONDENSATRICE REMOTA SEMIERMETICA	
		CONDENSING UNIT INCLUDED			CONDENSING UNIT EXCLUDED	REMOTE CONDENSING UNIT INCLUDED <i>up to 20 meters</i>		REMOTE CONDENSING UNIT INCLUDED	
		ARIA AIR	ACQUA WATER	ARIA-ACQUA AIR - WATER		ARIA AIR	ARIA-ACQUA AIR - WATER	ARIA AIR	ARIA-ACQUA AIR - WATER
H117									
120	KAG0012000L								
170	KAG0017000L								
120+50	COMBI KAG0120500L								
220	KAG0022000L								
170+50	COMBI KAG0170500L								
AE 45	KAG0AE4500L								
H135									
120	KAG0012000L								
170	KAG0017000L								
120+50	COMBI KAG0120500L								
220	KAG0022000L								
170+50	COMBI KAG0170500L								
AE 45	KAG0AE4500L								

ESCLUSO: - KIT VASCHE GELATO - PANNELLO FRONTALE
NOT INCLUSIVE OF: -ICE-CREAM CONTAINERS KIT - FRONT PANEL

INCLUSO: - IMBALLO
INCLUSIVE OF: - PACKAGING

● OPTIONAL

	Modello Model	Codice Code
● Portaconi completo grigio	Grey cone holder	9001390900802
● Portaconi completo di vaschette portagranelle	Cone holder complete of toppings container	9001390900801
● Consolle lavaporzionate con rubinetto DX	Consolle scoop washer with water tap DX	9001920000267
● Consolle lavaporzionate con doccetta avvolgitubo DX	Consolle scoop washer with shower selfrolling DX	9001920000268
● Kit ruote movimentazione vetrina (solo moduli lineari)	Wheel kit for easy handing (only linear modules)	120 9001390900813
● Kit ruote movimentazione vetrina (solo moduli lineari)	Wheel kit for easy handing (only linear modules)	170, 220 9001390900814
● Vaschetta portaghiaccioli (250x360x43H) Q.tà 1	Ice lolly container (250x360x43H) Q.ty 1	9001990000014
● Vassoio inox (495x360) Q.tà 1	Stainless Steel tray (495x360) Q.ty 1	120, 170, 220 9001390900815
● Kit Vassoio inox (3+3)	Stainless Steel tray kit (3+3)	AE45
● Vassoio monoporzioni (250x360) Q.tà 1	Tray portion (250x360) Q.ty 1	120, 170, 220, AE45 9001390900816
● Kit tubazioni per UCR - al metro lineare	Piping kit for Remote Condensing Unit - each meter	9006000000007

● VARIANTI EQUIPMENT

	Modello Model
● Illuminazione frontalino RGB	120
Lighting RGB front side	170
	220
	AE 45
● Illuminazione basamento elettronica a LED	120
Electronic lighting with LED basement	170
	220
	AE 45

■ Pannelli frontali disponibili standard

Display kit Available front panels standard

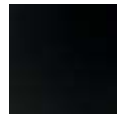

Vetro Nero



Rosso
Lacca Cinese



Pelle di Struzzo



Alicrite

MODELLO MODEL

120

170

220

AE 45

OPTIONAL: KIT VASCHE INOX
STAINLESS STEEL CONTAINERS KIT

● 360 x 165 x 120H
Litri Liters 5



● 360 x 250 x 80H
Litri Liters 5



● 360 x 185 x 120H **TRAPEZOIDALI**
Litri Liters 5



Modello Model	Quantità Quantity	Codice Code	Quantità Quantity	Codice Code	Quantità Quantity	Codice Code
120	12	9001090900019	8	9001090900027		
170	18	9001090900023	12 (1)	9001090900029		
220	24	9001090900026	16	9001090900031		
AE 45	13	9001090900020	9 (5)	9001090900101	4 (6)	90010909001

Componibilità Kit vaschette vasca esposizione
Display kit containers arrangement

120 **170** **220** **AE 45**

lt 5
(360x165x120H)

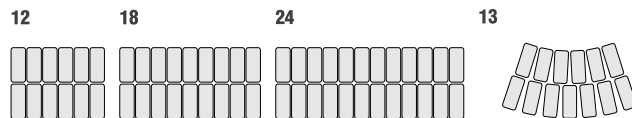

lt 5
(360x250x80H)

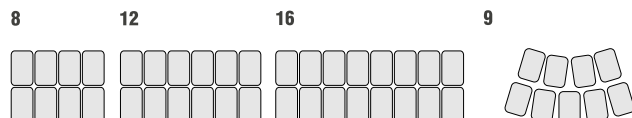

lt 5
(360x185x120H) **TRAPEZOIDALI**

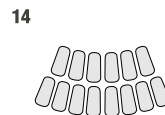

COMBI **170 (50+120)** **220 (50+170)**

lt 5
(360x165x120H)



+

lt 5
(360x165x120H)

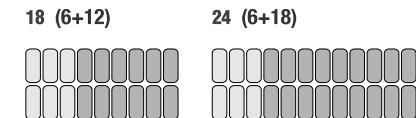

lt 5
(360x165x120H)



+

lt 5
(360x250x80H)

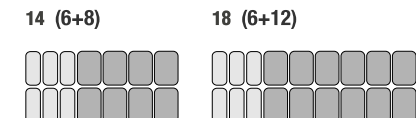

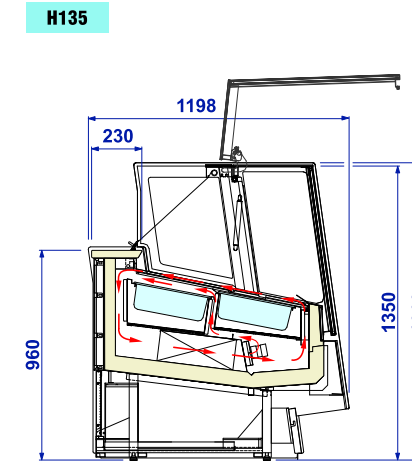
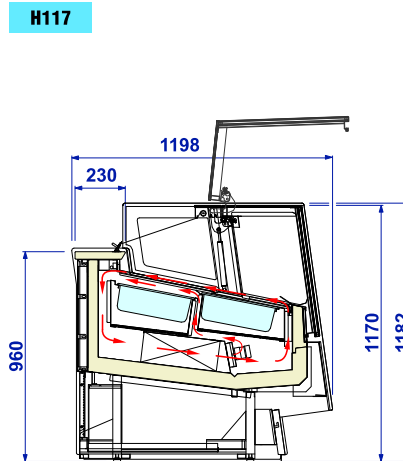

Caratteristiche Tecniche
Technical features

Dimensioni esterne (lpxh)	External dimensions (lxdxh)	mm	H117
		mm	H135
Capacità (lorda-netta)	Capacity (gross - net)	lt	H117
		lt	H135
Temperatura di regolazione	Cabinet capacity range	°C	
Temperatura prodotto	Product temperature	°C	
Sbrinamento	Defrost		
Classe climatica	Climatic class	N°	
Condizioni ambientali	Operating conditions	°C / %RH	
Compressore (Tipo - n°)	Compressor (type - n°)		
Alimentazione	Power supply	V / ph / Hz	
Assorbimento elettrico (regime)	Electrical input (standard)	W / A	
Assorbimento elettrico (sbrinamento)	Electrical input (defrost)	W / A	
Peso netto	Net weight	kg	H117
		kg	H135

120	170	220	AE 45	170 (50+120)	220 (50+170)
RV	RV	RV	RV	RV	RV
				COMBI	COMBI
1182 x 1198 x 1182	1677 x 1198 x 1182	2172 x 1198 x 1182	1875 x 1198 x 1182	1677 x 1198 x 1182	2172 x 1198 x 1182
1182 x 1198 x 1362	1677 x 1198 x 1362	2172 x 1198 x 1362	1875 x 1198 x 1362	1677 x 1198 x 1362	2172 x 1198 x 1362
Ventilata Ventilated	Ventilata Ventilated	Ventilata Ventilated	Ventilata Ventilated	Ventilata Ventilated	Ventilata Ventilated
685 / 147	1009 / 216	1332 / 285	901 / 193	1009 / 216	1332 / 285
824 / 147	1212 / 216	1600 / 285	1082 / 193	1212 / 216	1600 / 285
-20 / +2	-20 / +2	-20 / +2	-20 / +2	-20 / +2	-20 / +2
-16 / -14	-16 / -14	-16 / -14	-16 / -14	-16 / -14	-16 / -14
Inversione Ciclo Reverse cycle	Inversione Ciclo Reverse cycle	Inversione Ciclo Reverse cycle	Inversione Ciclo Reverse cycle	Inversione Ciclo Reverse cycle	Inversione Ciclo Reverse cycle
4+	4+	4+	4+	4+	4+
35 / 70	35 / 70	35 / 70	35 / 70	35 / 70	35 / 70
Ermetico (1) Hermetic (1)	Ermetico (2) Hermetic (2)	Ermetico (2) Hermetic (2)	Ermetico (2) Hermetic (2)	Ermetico (2) Hermetic (2)	Ermetico (2) Hermetic (2)
230 / 1 / 50	400 / 3 / 50	400 / 3 / 50	400 / 3 / 50	400 / 3 / 50	400 / 3 / 50
1240 / 6	1510 / 7	2350 / 11	1510 / 7	1510 / 7	2350 / 11
2300 / 11	2560 / 12	3890 / 19	2560 / 12	2560 / 12	3890 / 19
320	409	510	400	409	510
346	434	535	425	434	535